

# F-1000 exploded view and parts list

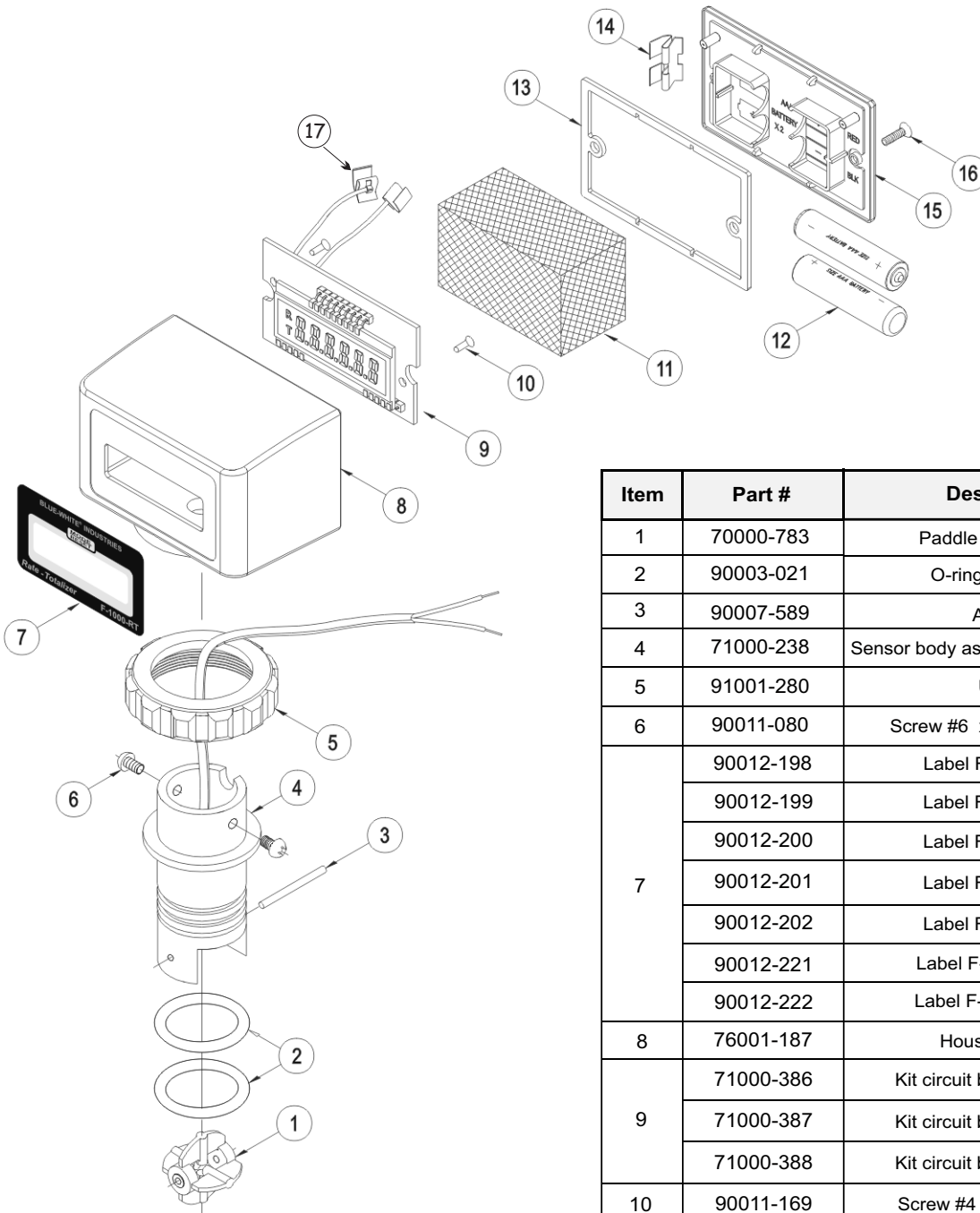

Item	Part #	Description	Qty
1	70000-783	Paddle assembly PVDF	1
2	90003-021	O-ring 022 Viton E60	2
3	90007-589	Axle PVDF	1
4	71000-238	Sensor body assembly F-1000 no paddle	1
5	91001-280	Union nut	1
6	90011-080	Screw #6 x .37 PH Pan B 18/8	2
7	90012-198	Label F-1000-RB GPM	1
	90012-199	Label F-1000-RB GPH	1
	90012-200	Label F-1000-RB LPM	1
	90012-201	Label F-1000-RB LPH	1
	90012-202	Label F-1000-RB M <sup>3</sup> H	1
	90012-221	Label F-1000-TB overlay	1
	90012-222	Label F-1000-RT overlay	1
8	76001-187	Housing F-1000	1
9	71000-386	Kit circuit board F-1000-RB	1
	71000-387	Kit circuit board F-1000-RT	1
	71000-388	Kit circuit board F-1000-TB	1
10	90011-169	Screw #4 x .25 Phil Pan "A"	2
11	90013-260	Foam pad 1.25 x 1.25 x 2.25	1
12	90008-318	Battery each AAA	2
13	90006-590	Gasket F-1000	1
14	90008-319	Battery clip F-1000	1
15	90002-203	Rear plate F-1000	1
16	90011-113	Screw #4 x .50 Phil oval "A"	2
17	90010-241	Battery Connector	1