

C-1500N STAR SYSTEM

7, 15, 30 GALLON

Heavy Duty 0.30" wall



Features:

- Extra heavy 0.30" thick wall polyethylene with UV inhibitors.
- Ships complete with the C-1500N pump model of your choice.
- 3 tank capacities to choose from: 7, 15, and 30 gallons.
- Molded-in threaded inserts and raised shelf for sturdy pump mounting.
- Lid positions include open, closed and vent.
- All necessary accessories are included.
- Convenient space saving rectangular shape.
- Raised off the floor for easy wash down.

Specifications:

Material:LLDPE
Capacity:7, 15, or 30 U.S. Gallons
Max. fluid temperature:130° F (54° C)
Max. ambient temperature: ..14° to 110° F/ -10° to 43° C
Approximate shipping wt: ...(includes C-1500N pump)
7 gallon units = 19 lb. (8.6 kg)
15 gallon units = 28 lb. (12.7 kg)
30 gallon units = 36 lb. (16.3 kg)

Materials of Construction:

Tank system only:

Tank:Natural Polyethylene (LLDPE)

Suction Strainer assembly:

Tubing:Clear PVC
Weight:Ceramic
Footvalve adapter & body: PVDF
Strainer screen:Polypropylene
Check Ball:Ceramic
Spring:Hastelloy C-276
Ball Seat O-ring:TFE/P (optional EP)
Static Seal O-ring:Viton[®] (optional EP)Natural
Lid:Polypropylene
Lid fasteners:Polypropylene

Blue-White Industries, Ltd.

CHEM-FEED® Diaphragm Metering Pumps

Dimensions:

DIMENSIONS = INCH (CM)

	DIM 'A'	DIM 'B'	DIM 'C'	DIM 'D'	DIM 'E'	TANK SHIP WT.
7 GALLON TANK	17.5 (44.5)	12.0 (30.5)	16.0 (41.0)	7.8 (19.7)	17.0 (43.0)	11 LB. (5.0 Kg)
15 GALLON TANK	22.0 (56.0)	15.5 (39.0)	19.5 (50.0)	7.8 (19.7)	17.0 (43.0)	20 LB. (9.1 Kg)
30 GALLON TANK	27.0 (69.0)	20.0 (51.0)	24.0 (61.0)	7.8 (19.7)	17.0 (43.0)	28 LB. (12.7 Kg)

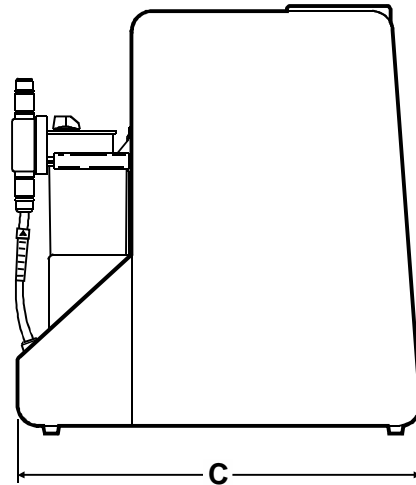
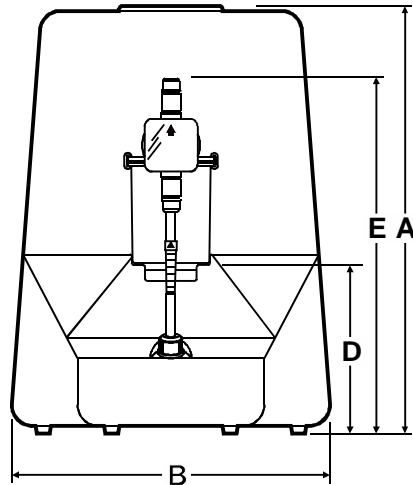

Complete System Model Number Matrix:

MODEL T15N

Maximum Motor RPM	
0 = 14 RPM	3 = 60 RPM
1 = 30 RPM	4 = 125 RPM
2 = 45 RPM	
Power Supply (motor protection)	
0 = 115V60Hz (IP)	4 = 115V60Hz (TP)
1 = 220V50Hz (IP)	5 = 220V50Hz (TP)
2 = 230V60Hz (IP)	6 = 230V60Hz (TP)
3 = 24V60Hz (IP)	7 = 24V50Hz (none)*
	8 = 240V50Hz (TP)
IP = impedance protection, TP = Thermal protection * intermittent duty only	
Cam Stroke Length	
1 = .125"	3 = .187"
2 = .055"	4 = .100"
Output Control & Electrical	
X = Standard Equipment	
I = Analog timer, 5 sec. Cycle - 100% duty	
K = Analog timer, 60 sec. Cycle - 100% duty	
A = Junction box replaces power cord	
C = On/Off switch and junction box	
P = Power cord and junction box	
R = 230V Power cord w/NEMA 6/15 plug	
T = 230V Power cord and on/off switch	
Z = Proportional feed system - JBox/Cord	

Tank Capacity	
1 = 7 Gallons (U.S.)	
2 = 15 Gallons (U.S.)	
3 = 30 Gallons (U.S.)	
Injection Fitting	
0 = A-014N (Polypropylene - ½ lb spring)	
1 = C-395N (Polypropylene - 6 lb spring)	
A = A-014-6T (PTFE - ½ lb spring)	
B = C-395-6T (PTFE - 6 lb spring)	
C = A-014NK (PVDF - ½ lb spring)	
D = C-395NK (PVDF - 6 lb spring)	
Elastomer Material	
V = Viton E = EP	
Diaphragm Style	
0 = Large PTFE/EP 6 = Small PTFE / EP	
1 = Large PTFE/Viton 7 = Small PTFE / EP	
Pump Head Style	
0 = Large Diaphragm 4 = Large Diaphragm Carwash	
2 = Small Diaphragm 6 = Small Diaphragm Carwash	
5 = Large Pressure release	
Pump Head Material	
0 = Injection molded PVDF	
4 = Machined PTFE	
5 = Machined Acrylic	

Tank Only Model Number:

STAR-7 = 7 gallon tank only
 STAR-15 = 15 gallon tank only
 STAR-30 = 30 gallon tank only