

# Installation Instructions F-450N

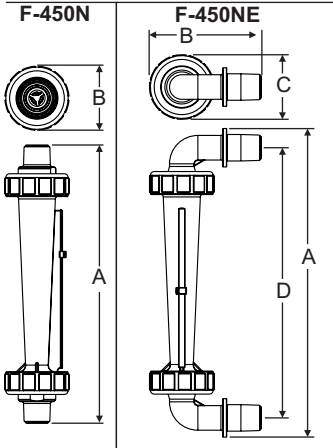

**F-450NA**

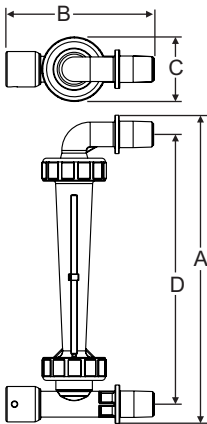

	Model No.	Dim A	Dim B	Dim C	Dim D
<b>Inline</b>	F-45375 F-45376 F-45500	8-7/8" 225.5mm	1-3/4" 44.4mm	N/A	N/A
	F-45750	10" 254mm	2" 51mm	N/A	N/A
	F-45375E F-45376E F-45500E	9-7/8" 250.8mm	3-1/2" 88mm	2" 51mm	8-9/16" 217.5mm
<b>Elbow</b>	F-45750E	10" 254mm	3-1/2" 88mm	2" 51mm	9-1/8" 231.8mm
	F-45375A F-45376A F-45500A	9-7/8" 250.8mm	5" 127mm	2" 51mm	8-9/16" 217.5mm
<b>Adjustable</b>	F-45750A	10" 254mm	5" 127mm	2" 51mm	9-1/8" 231.8mm

**Meter Body:** Polysulfone

**Float:** 316SS, Hastelloy C-276, PVDF, or PTFE (based on model)

**Guide rod:** # 316 Stainless (opt. Hastelloy C-276)

**Adapters:** Polysulfone

**O-Rings:** Viton (optional EP)

**Scale:** Permanent, dual scale silkscreen (black ink)

**Max. PSIG:** 175 PSIG / 12 BAR at 70°F/21°C

**Max. Temp:** 212°F / 100°C at 0 pressure

**Accuracy:** ± 4% of full scale reading

## Your Blue-White® F-450 Series

- Your Blue-White® flowmeter was designed to be easy to install.
- Please read the Instruction Guideline on the next page before installing your flowmeter.
- This flowmeter is an instrument, special care should be taken when handling and installing.

## Inspection of the Flowmeter and Compatibility

- Carefully inspect the meter for any damage that may have occurred during shipping.
- Remove the plastic tubing that has been inserted during packaging for shipping reasons.
- Make sure your pressure, temperature, fluid and other requirements are compatible with the meter before installation.
- The maximum temperature capability decreases as the pressure increases. The max PSI decreases as the temperature increases. See the chart on the following page.
- Although the meter may be suitable for other chemicals, Blue-White® meters are tested with water. If you are unsure of the meters compatibility with your chemical, please consult the factory.
- Blue-White® warranties the flowmeter for use with water only.

**Blue-White**  
Industries, Ltd.

---

## Installation Guideline

**Caution:** Follow these instructions to avoid failure.

**Danger:** Wear eye protection when installing or removing flowmeter.

### 1. Misalignment will damage the meter!

Flowmeter must be installed in an exact vertical plane to ensure accuracy. Be certain of proper plumbing alignments. Misalignment may cause the o-ring seals to leak. The meterbody material can be damaged by UV rays. **Do not install in direct sunlight.**

### 2. Pipe dope and glue will damage the meter!

Use only PTFE tape on the threaded adapters. Polysulfone meter body and fittings cannot tolerate PVC Glue and/or pipe dope. Even fumes can cause severe damage. If you are installing your flowmeter to a glued pipe configuration, install the flowmeter *after* all glued fittings are dried and lines are purged of all fumes. **Never** hold the meter body with pliers or like tools. Union nuts should be hand tightened only. **DO NOT OVER-TIGHTEN!**

### 3. Vibration and heavy loads will damage the meter!

Wall, floor and ceiling mounts and supports must be carefully aligned with the meter body and sturdy enough to support the plumbing and prevent vibration. Never allow the flowmeter to support the weight of related piping.

### 4. Solenoid valves will damage the meter!

**Avoid a system that will impose a sudden burst of flow to the meter.** Such a burst will cause the float to impact the float stop with destructive force. Solenoid valves, or other quick opening valves cannot be used unless meter is protected against sudden bursts of flow.

### 5. High pressures and temperatures will damage the meter!

The maximum acceptable temperature and pressure is interdependent. The maximum acceptable working pressure is dependant on the actual fluid temperature. The maximum acceptable fluid temperature is dependant on the actual working pressure. (see Temperature Vs. Pressure chart).

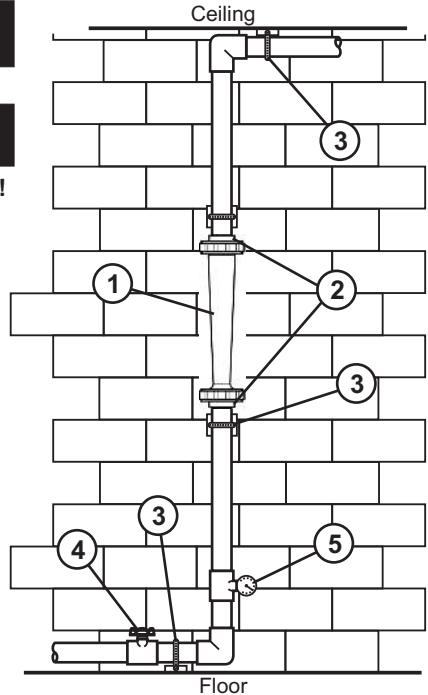

---

## Temperature vs. Pressure

### Temperature

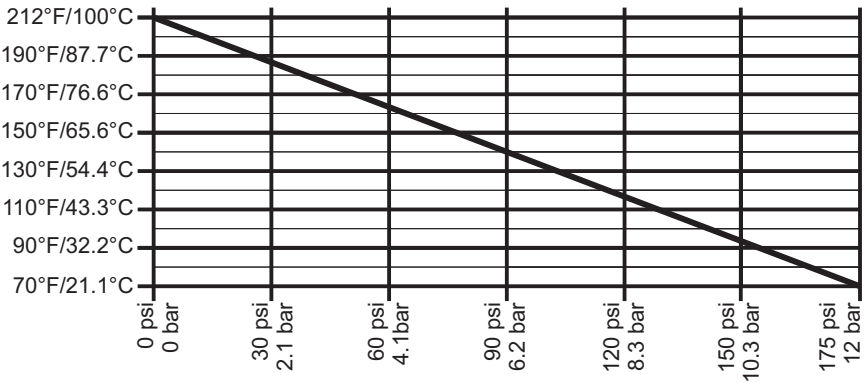

### Pressure and Temperature

Pressure and temperature limits are inversely proportional. At the maximum suggested pressure the temperature should approach 70°F / 21.1°C; at the maximum suggested temperature the pressure should approach zero psi. We cannot guarantee our flowmeters will not be damaged either at or below the suggested limits simply because of many factors which influence meter integrity; stress resulting from meter misalignment, damage due to excessive vibration and/or deterioration caused by contact with certain chemicals as well as direct sunlight. These situations and others tend to reduce the strength of the materials from which the meters are manufactured.

---

### Application Note

**Flowmeters are tested and calibrated for water only.**

**Although meters may be suitable for other chemicals, Blue-White cannot guarantee their suitability. It is the responsibility of the user to determine the suitability of the flowmeter in their application.**

---

### Maintenance

The "Exploded View" drawing illustrates assembly of the F-450 series meter. If your flowmeter needs to be cleaned refer to this drawing when reassembling the unit. The tapered tube may be cleaned with a soft bottle brush. Use a MILD soap and water solution for cleaning purposes. Hard water deposits can be removed with a 5% acetic acid solution (vinegar). Note the floats "up" position.

## F-450N - In-Line

No.	Part No.	Desc.
1	F-45N011	3/8" Male NPT in-line adapter, Polysulfone
	F-44N011	1/2" Male NPT in-line, Polysulfone
	F-45N048	1/2" Male NPT in-line, Brass
	F-44N008	1/2" SWEAT in-line, Brass
	F-44N09	3/4" Male NPT in-line, Polysulfone
	F-44N25	3/4" Male NPT in-line, Brass
2	F-44N06	3/4" Half Union, Nylon
	F-44N06AL	3/4" Half Union, Aluminum
4		
	90003-082	O-ring seal, Viton
	90003-039	O-ring seal, EP
5	N/A	Meterbody and Float not sold separately
6	F-45N005	F-45375, F-45376, F-45500 Guide Rod 316 ss
	F-45N021	F-45750 Guide Rod, 316 ss
	F-45N005H	F-45375, F-45376, F-45500 Guide Rod Hastelloy C-276
	F-45N021H	F-45750, Guide Rod Hastelloy C-276
7	F-45N007	3/8" and 1/2" Guide Rod holder, Polysulfone
	F-45N019	3/4" Guide Rod holder, Polysulfone
11	F-45N043	Indicator, Red

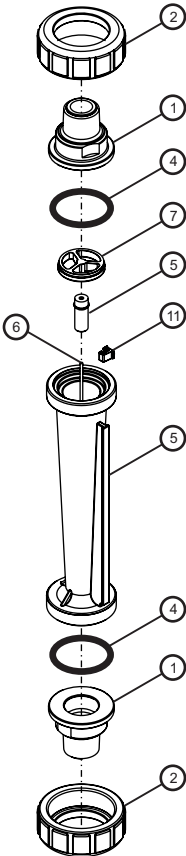

## F-450NE - Elbow (Panel Mount)

No.	Part No.	Desc.
1	F-44N41	3/8" Male NPT 90° Elbow, Polysulfone
	F-44N42	1/2" Male NPT 90° Elbow, Polysulfone
	F-44N21	3/4" Male NPT 90° Elbow, Polysulfone
2	F-44N06	3/4" Half Union, Nylon
3	F-4427A	3/8" and 1/2" Panel mount lock nut
	F-4428A	3/4" Panel mount lock nut
4	90003-082	O-ring seal, Viton
	90003-039	O-ring seal, EP
5	N/A	Meterbody and Float not sold separately
6	F-45N005F	45375, F-45376, F-45500 Guide Rod 316 ss
	F-45N021	F-45750 Guide Rod, 316 ss
6	F-45N005H	F-45375, F-45376, F-45500 Guide Rod Hastelloy C-276
	F-45N021H	F-45750 Guide Rod, Hastelloy C-276
7	F-45N007	3/8" and 1/2" Guide Rod holder, Polysulfone
7	F-45N019	3/4" Guide Rod holder, Polysulfone
11	F-45N043	Indicator, Red

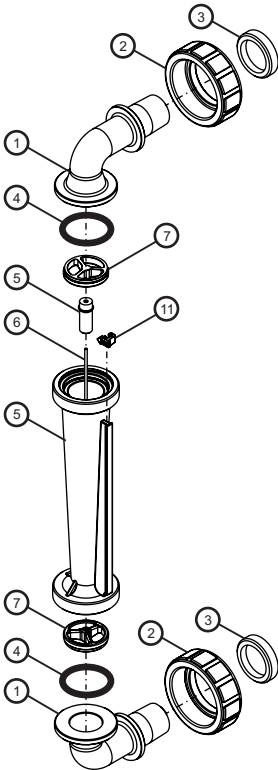

# F-450NA - Adjustable (Panel Mount)

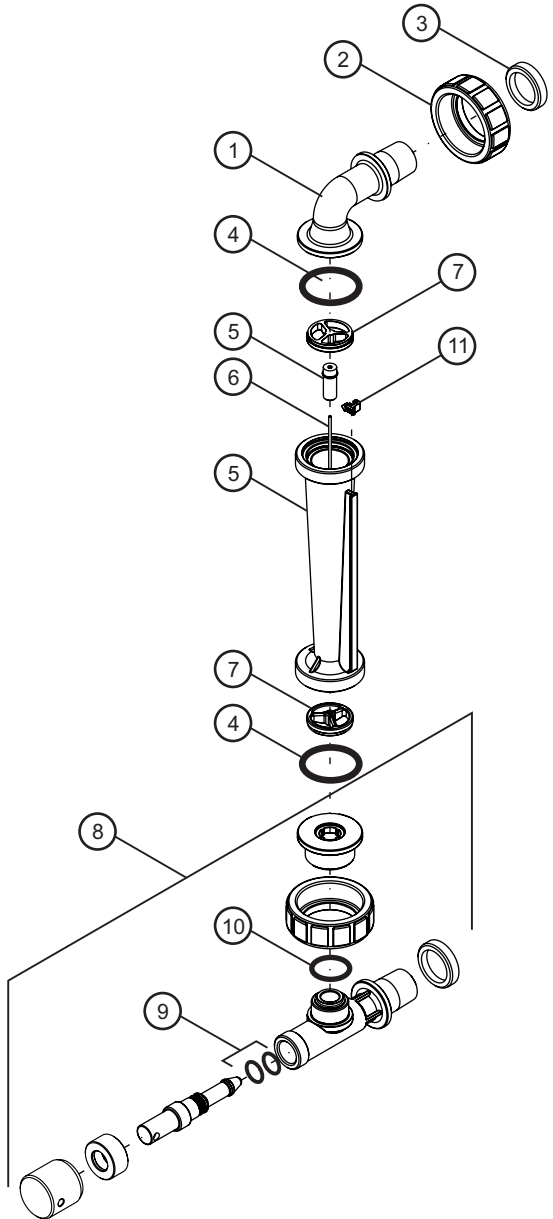

## F-450NA - Adjustable (Panel Mount)

No.	Part No.	Desc.
1	F-44N41	3/8" Male NPT 90° Elbow, Polysulfone
	F-44N42	1/2" Male NPT 90° Elbow, Polysulfone
	F-44N21	3/4" Male NPT 90° Elbow, Polysulfone
2		
	F-44N06	3/4" Half Union, Nylon
3	F-4427A	3/8" and 1/2" Panel mount lock nut
	F-4428A	3/4" Panel mount lock nut
4		
	90003-082	O-ring seal, Viton
	90003-039	O-ring seal, EP
5	N/A	Meter body and Float not sold separately
6	F-45N005	F-45375, F-45376, F-45500 Guide Rod, 316 ss
6	F-45N021	F-45750 Guide Rod, 316 ss
6	F-45N005H	F-45375, F-45376, F-45500 Guide Rod, HastelloyC-276
6	F-45N021H	F-45750 Guide Rod, Hastelloy C-276
7	F-45N019	3/4" Guide Rod holder, Polysulfone
8	F-45N031-1	3/8" M/NPT Valve Assm. large, Poly, Viton Seals
8	F-45N031-2	1/2" M/NPT Valve Assm. large, Poly, Viton Seals
8	F-45N031-3	3/4" M/NPT Valve Assm. large, Poly, Viton Seals
9	90003-010	O-ring, Viton
9	90003-009	O-ring, EP
10	90003-018	O-ring, Viton
10	90003-071	O-ring, EP
11	F-45N043	Indicator, Red

---

## **BLUE-WHITE INDUSTRIES LIMITED WARRANTY**

**FLOWMETERS** are warranted to be free of defects in material and workmanship for up to 12 months from the date of factory shipment. Warranty coverage is limited to repair or replacement of the defective flowmeter only. Blue-White Industries does not assume responsibility for any other damage that may occur.

This warranty does not cover damage to the flowmeter that results from misuse or alterations, nor damage that occurs as a result of: meter misalignment, improper installation, over tightening, use of non- recommended chemicals, use of non-recommended adhesives or pipe dopes, excessive heat or pressure, or allowing the meter to support the weight of related piping. Flowmeters are tested and calibrated with water only. Although meters may be suitable for other chemicals, Blue-White cannot guarantee their suitability.

Flowmeters are repaired at the factory only. Call or write the factory to receive a Return Authorization Number, carefully pack the flowmeter to be returned, including a brief description of the problem. Note the RA number on the outside of the carton.

---

Website: [www.Blue-White.com](http://www.Blue-White.com)

E-mail: [Sales@Blue-White.com](mailto:Sales@Blue-White.com) | [Techsupport@Blue-White.com](mailto:Techsupport@Blue-White.com)

Phone: 714-893-8529 | Fax: 714-894-9492

**Blue-White**<sup>®</sup>  
**Industries, Ltd.**

5300 Business Drive  
Huntington Beach, CA 92649

---