

GEN NOTES:
 1.
 2.
 3.

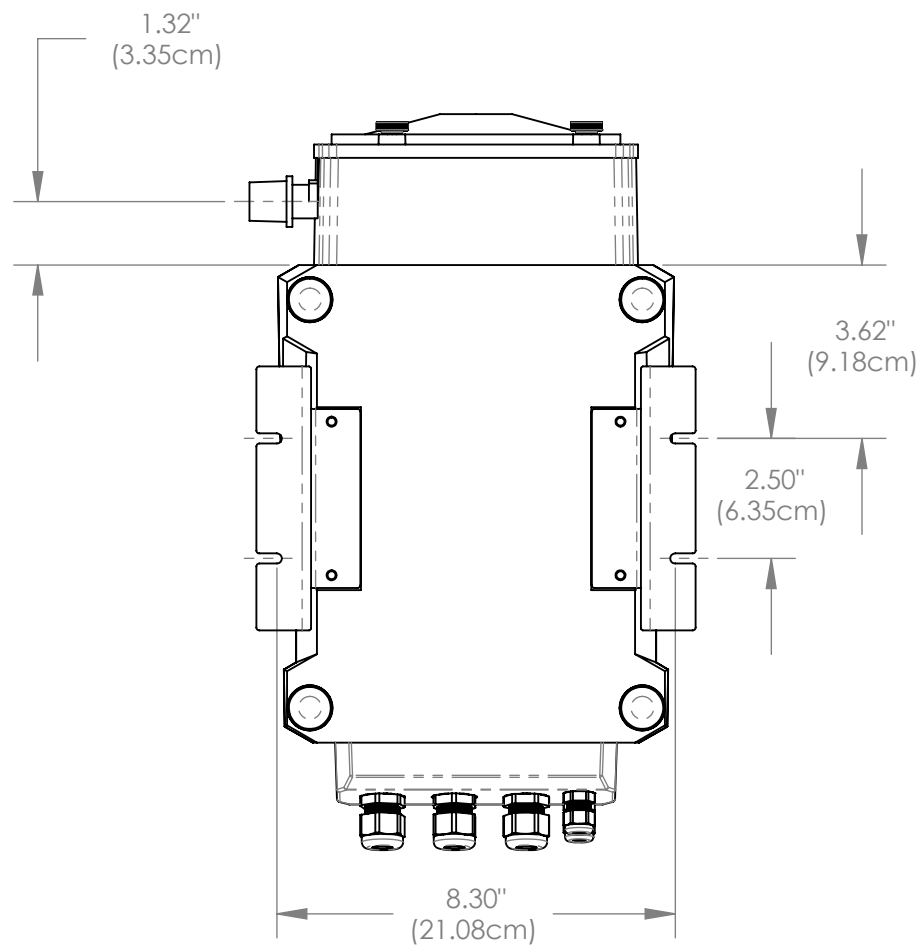
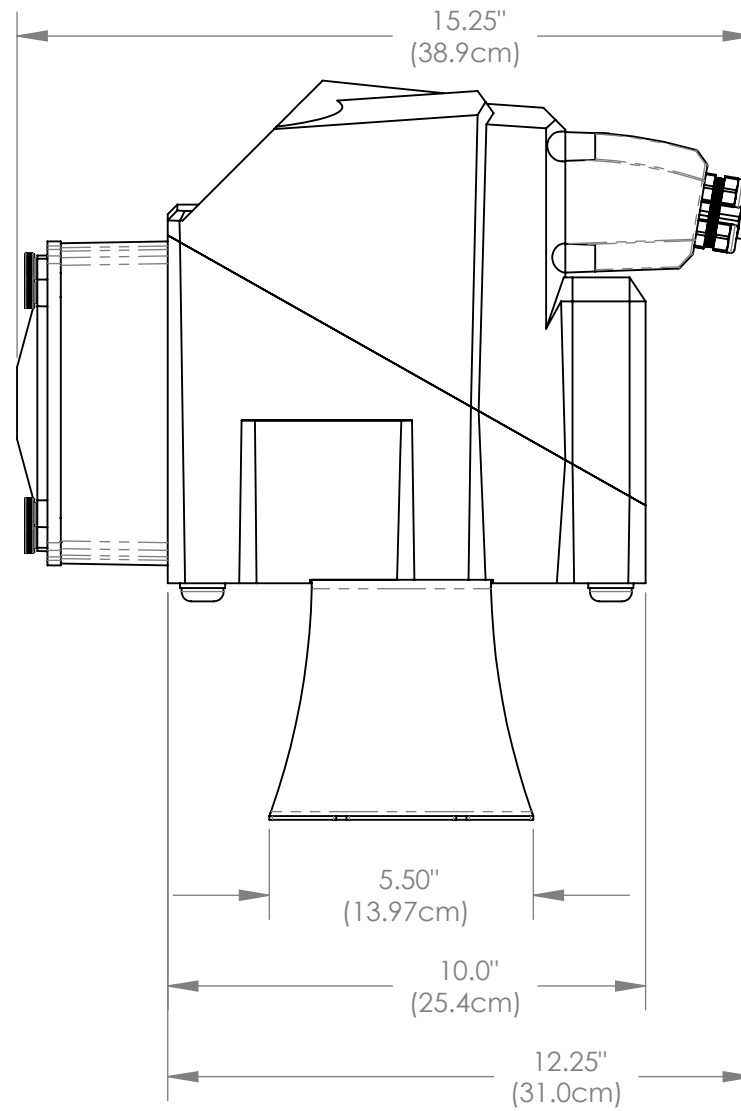
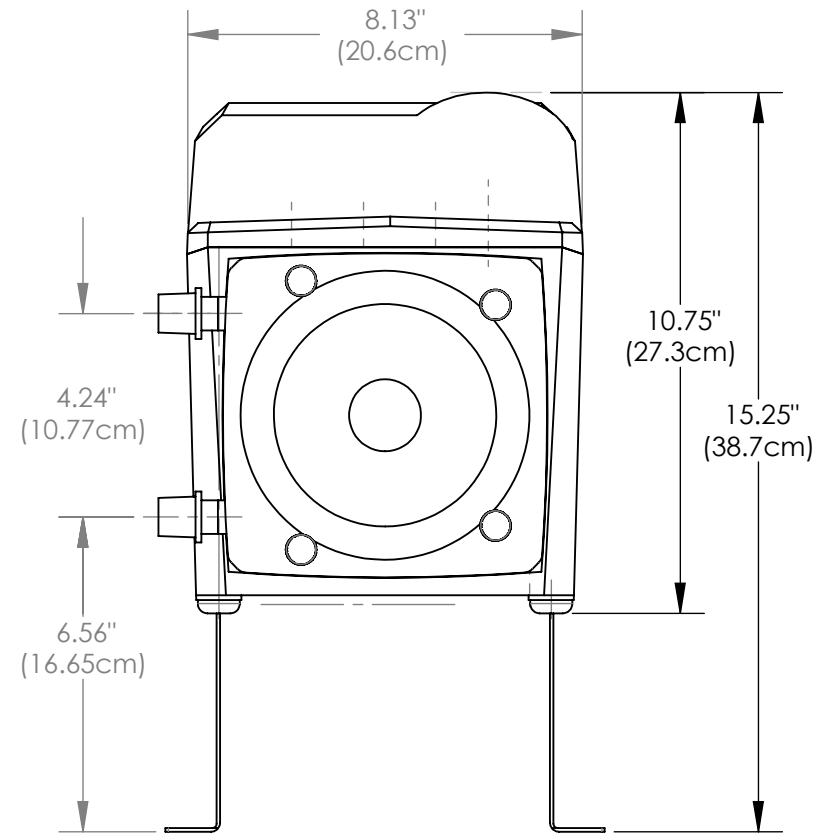

REVISIONS				
ZONE	REV.	DESCRIPTION	DATE	APPROVED

UNLESS OTHERWISE SPECIFIED:
 DIMENSIONS ARE IN INCHES
 ALL ANGLES 45°
 TOLERANCES:
 FRACTIONAL ±1/64
 ANGULAR: MACH ±1° BEND ±1°
 TWO PLACE DECIMAL ±.010
 THREE PLACE DECIMAL ±.005

INTERPRET GEOMETRIC TOLERANCING PER:
 MATERIAL
 FINISH
 DO NOT SCALE DRAWING

	NAME	DATE
DRAWN	REG III	6-8-10
CHECKED		
ENG APPR.		
MFG APPR.		
Q.A.		
COMMENTS:		

BLUE-WHITE INDUSTRIES
 5300 BUSINESS DRIVE HUNTINGTON BEACH CA, 92649

TITLE:
 Flex-Pro, A3, Extended Brackets

SIZE	DWG. NO.	REV
B	CA3_Assem_Cust_Ext	-
SCALE: 1:4	WEIGHT:	SHEET 1 OF 1

PROPRIETARY AND CONFIDENTIAL
 THE INFORMATION CONTAINED IN THIS DRAWING IS THE SOLE PROPERTY OF **BLUE-WHITE INDUSTRIES**. ANY REPRODUCTION IN PART OR AS A WHOLE WITHOUT THE WRITTEN PERMISSION OF **BLUE-WHITE INDUSTRIES** IS PROHIBITED.

NEXT ASSY	USED ON
APPLICATION	DO NOT SCALE DRAWING